

# Flow Sleeve for C-SJ Pumps

## Device to protect the pump from dirt and for motor cooling

A flow sleeve is a sleeve that goes around the pump body and motor. It has two functions:

1. **A flow sleeve reduces the amount of dirt in the pump.** Where water sources contain sand or have the potential for dirt falling into them (uncapped wells) a flow sleeve is recommended to protect the pump from dirt. Due to the large inner diameter of the flow sleeve the water rises very slowly and dirt deposits at the bottom of the well. Subsequently, water with less sediments enters the pump which increases its lifetime.
2. **A flow sleeve cools the motor.** In open water, tanks or pools there is no natural flow of water across the motor which can lead to heat build-up. The tube enforces water flow across the motor which has a cooling effect.

## FEATURES

- Due to the large inner diameter of the flow sleeve the water rises very slowly allowing dirt to settle at the bottom of the well
- The life expectancy of the pump is increased due to less sand entering the pump
- Simple installation
- The flow sleeve must be selected according to the pump system (see table)
- The required borehole diameter depends on the diameter of the flow sleeve

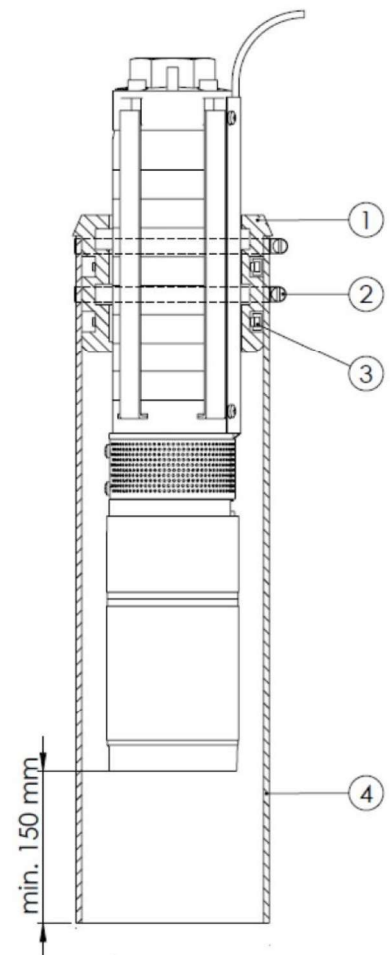

## ORDER INFORMATION (please compare (1), (2) etc. with the sample flow sleeve)

Item no.	Product name	Scope of delivery	Suitable for
19-000230	Flow Sleeve Kit for 4" C-SJ Pumps with 4" Motor	(1) 1 x adaptor (2) 2 x hose clamp (3) 2 x cable strip (4) 1 x PVC tube: D140x4, 0.5 m length	All 4" C-SJ pump ends with 4" motor
19-000250	Flow Sleeve Adaptor for 4" C-SJ Pumps with 4" Motor	(1) 1 x adaptor (2) 2 x hose clamp (3) 2 x cable strip  A PVC tube D140x4mm (4) is not part of the scope of delivery.	All 4" C-SJ pump ends with 4" motor
19-000255	Flow Sleeve Adaptor for C-SJ17-X/30-X with 4" motor	(1) 1 x adaptor (2) 2 x screw 4.2x16 (3) 1 x hose clamp  A PVC tube D160x4mm (4) is not part of the scope of delivery.	All C-SJ17-X/30-X with 4" motor
19-005170	Flow Sleeve Kit for C-SJ42-X Pumps	(1) 1 x adaptor (2) 2 x hose clamp d =190-210 mm (3) 2 x hose clamp d= 150-170 mm (4) 1 x PVC tube: D200x5, 1.4 m length	All C-SJ42-X pumps
19-005180	Flow Sleeve Adaptor for C-SJ42-X Pumps	(1) 1 x adaptor (2) 2 x hose clamp d=190-210 mm (3) 2 x hose clamp d=150-170 mm  A PVC tube D200x5mm (4) is not part of the scope of delivery.	All C-SJ42-X pumps
19-001400	Flow Sleeve Kit for C-SJ8-x/12-x for 6" motor with tube	(1) 1x adaptor (2) 2x hose clamp d=190-210 mm (3) 2x hose clamp d=150-170 mm (4) 1x PVC tube: D200x5, 1,4m length	All C-SJ8-x and C-SJ12-x pumps with 6" motor
19-001450	Flow Sleeve Adaptor for C-SJ8-x/12-x for 6" motor	(1) 1x adaptor (2) 2x hose clamp d=190-210 mm (3) 2x hose clamp d=150-170 mm  A PVC tube D200x5mm (4) is not part of the scope of delivery.	All C-SJ8-x and C-SJ12-x pumps with 6" motor
19-001410	Flow Sleeve Kit for C-SJ17-x/30-x for 6" motor with tube	(1) 1x adaptor (2) 2x hose clamp d=190-210 mm (3) 2x hose clamp d=150-170 mm (4) 1x PVC tube: D200x5, 1,4m length	All C-SJ17-x and C-SJ30-x pumps with 6" motor
19-001460	Flow Sleeve Adaptor for C-SJ17-x/30-x for 6" motor	1x adaptor 2x hose clamp d=190-210 mm 2x hose clamp d=150-170 mm  A PVC tube D200x5mm (4) is not part of the scope of delivery.	All C-SJ17-x and C-SJ30-x pumps with 6" motor

## DIMENSIONS/WEIGHT

### Flow Sleeve Kit for 4" C-SJ Pumps with 4" Motor (19-000230):

- Packaging dimensions: 590 x 150 x 130 mm  
23.2 x 6.0 x 5.1 in sample flow sleeve
- Total weight: 3.3 kg / 7.3 lbs

### Flow Sleeve Adaptor for 4" C-SJ Pumps with 4" Motor (19-000250, without tube):

- Packaging dimensions: 165 x 165 x 110 mm  
6.5 x 6.5 x 4.3 in
- Total weight: 1.2 kg / 2.6 lbs

### Flow Sleeve Adaptor for C-SJ17-X/30-X with 4" motor (19-000255, without tube):

- Packaging dimensions: 165 x 165 x 110 mm  
6.5 x 6.5 x 4.3 in
- Total weight: 1.2 kg / 2.6 lbs

### Flow Sleeve Kit for C-SJ42-X Pumps (19-005170):

- Packaging dimensions: 1500 x 205 x 215 mm  
59.0 x 8.1 x 8.5 in
- Total weight: 9.3 kg / 20.6 lbs

### Flow Sleeve Adaptor for C-SJ42-X Pumps (19-005180, without tube):

- Packaging dimensions: 230 x 230 x 130 mm  
9.1 x 9.1 x 5.1 in
- Total weight: 1.9 kg / 4.2 lbs

### Flow Sleeve Kit for C-SJ8-X/12-X Pumps (19-001400):

- Packaging dimensions: 1510 x 215 x 235 mm  
59.4 x 8.4 x 9.2 in
- Total weight: 11 kg / 24.3 lbs

### Flow Sleeve Adaptor for C-SJ8-X/12-X Pumps (19-001450, without tube):

- Packaging dimensions: 220 x 220 x 130 mm  
8.6 x 8.6 x 5.1 in
- Total weight: 3 kg / 6.61 lbs

### Flow Sleeve Kit for C-SJ17-X/30-X Pumps (19-001410):

- Packaging dimensions: 1510 x 215 x 235 mm  
59.4 x 8.4 x 9.2 in
- Total weight: 11 kg / 24.3 lbs

### Flow Sleeve Adaptor for C-SJ17-X/30-X Pumps (19-001460, without tube):

- Packaging dimensions: 220 x 220 x 130 mm  
8.6 x 8.6 x 5.1 in
- Total weight: 3 kg / 6.61 lbs

#### BERNT LORENTZ GmbH

Siebenstuecken 24, 24558 Henstedt-Ulzburg, Germany  
Tel +49 (0)4193 8806-700, [www.lorentz.de](http://www.lorentz.de)

**Sun. Water. Life.**